

THIS DRAWING IS UNPUBLISHED. RELEASED FOR PUBLICATION
 © COPYRIGHT BY TYCO ELECTRONICS CORPORATION. ALL RIGHTS RESERVED.

LOC	DIST	REVISIONS			
P	LTR	DESCRIPTION	DATE	DWN	APVD
AF	50	K	REVISED PER ECR-06-010412	03NOV06	HMR KR

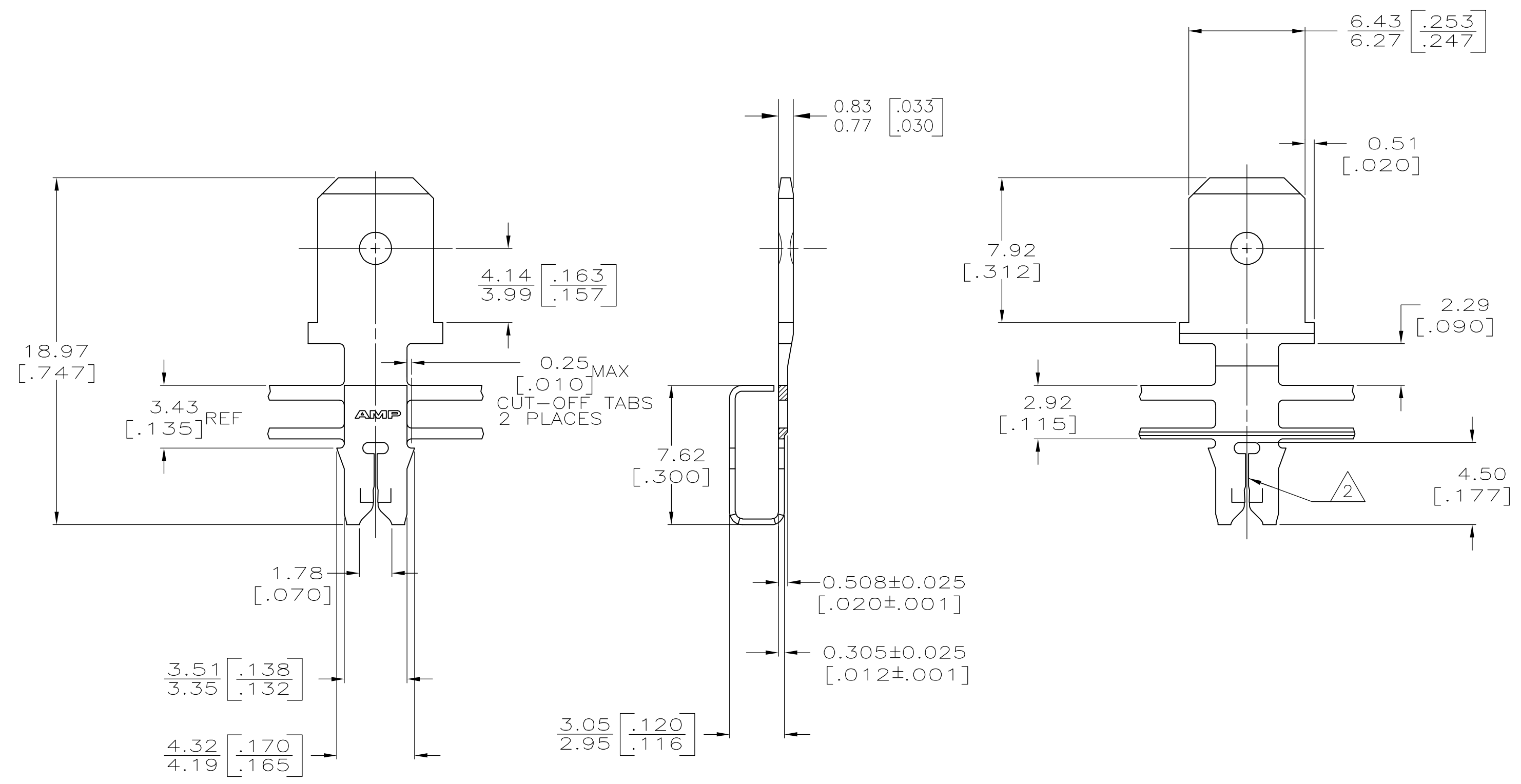

- CONTINUOUS STRIP ON REELS WITH TERMINALS LOCATED ON 8.38 [.330] CENTERS.
- SLOT TERMINATES EITHER SINGLE OR DOUBLE MAGNET WIRES OF THE SAME TYPE AND SIZE, COPPER RANGE IS 0.25-0.32mm [#30-#27] AWG.
- AFTER INSERTION INTO PLASTIC HOLDER TAB PORTION MUST BE BENT OVER 45° TO 90° OR POTTED-IN TO PREVENT PULL-OUT WHEN MATING RECEPTACLE IS DISCONNECTED.



62651-1
PART NO

THIS DRAWING IS A CONTROLLED DOCUMENT.		DWN MICHAEL S. FEHER 12/12/90	Tyco Electronics Corporation Harrisburg, PA 17105-3608	
DIMENSIONS: mm [INCHES]		CHK JEFF R. RUTH 12/20/90	NAME TAB, 6.35 [.250] FASTON™ MAG-MATE™	
TOLERANCES UNLESS OTHERWISE SPECIFIED:		APVD NELSON E. NEFF 12/20/90	PRODUCT SPEC	
0 PLC ± -		APPLICATION SPEC		
1 PLC ± -		114-2046		
2 PLC ± 0.25 [.010]		SIZE CAGE CODE DRAWING NO RESTRICTED TO		
3 PLC ± -		A2 00779 C-62651		
4 PLC ± -		WEIGHT -		
ANGLES ± ± -		CUSTOMER DRAWING		
MATERIAL #2 HARD PRE-MILLED BRASS		FINISH 0.002037 [.000080] MIN TIN PER MIL-T-10727		SCALE 5:1 SHEET 1 OF 1 REV K